

Powering Off and On

This chapter contains information necessary to prepare the system for servicing. Included are system power off and on, and external cable removal procedures.

<i>Powering Off the System</i>	<i>page 11-1</i>
<i>Removing the External Cables</i>	<i>page 11-3</i>
<i>Restarting the System</i>	<i>page 11-4</i>
<i>Reading Boot Messages</i>	<i>page 11-6</i>

11.1 Powering Off the System

Before turning off system power, halt the operating system as shown below. Failure to halt the operating system properly can cause the loss of disk drive data.

If you are troubleshooting system problems, you may find it convenient to reset the system or even cycle system power from the console. See Section 8.6.2, “Using a Remote Console,” on page 8-13.

- 1. Notify users that the system is going down.**
- 2. Back up the system files and data to tape, if necessary.**
- 3. Halt the system using the appropriate commands. Refer to the *Solaris Handbook for SMCC Peripherals* that corresponds to your operating system.**

4. Wait for the system-halted message and the boot monitor prompt.
5. Use the handle on the front of the Enterprise 3000 system and pull the front door open.
6. Locate the system keyswitch in the upper right corner, and turn the key switch to the Standby position (fully counterclockwise).
See Figure 11-1.
7. Turn the AC power switch on the system rear off.
This switch is on the peripheral power supply/AC that is installed in the far left corner. See Figure 11-2.

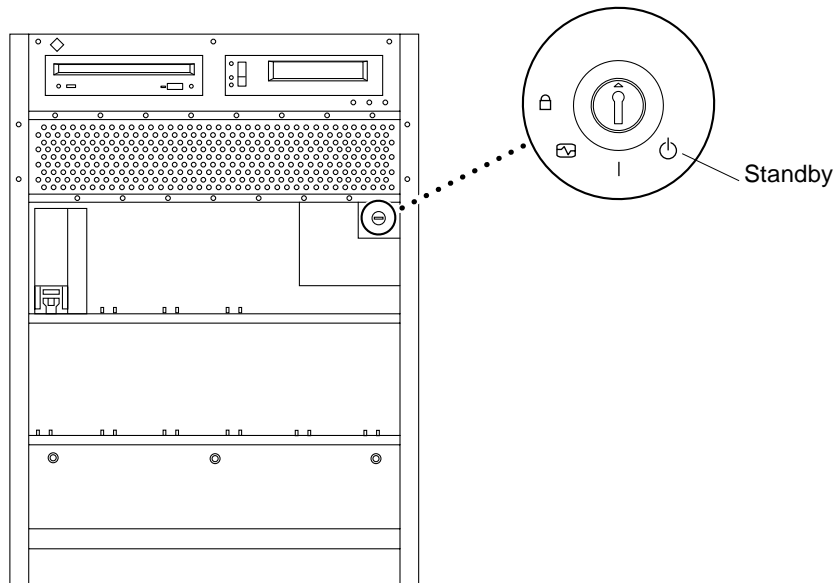

Figure 11-1 Keyswitch Standby Position

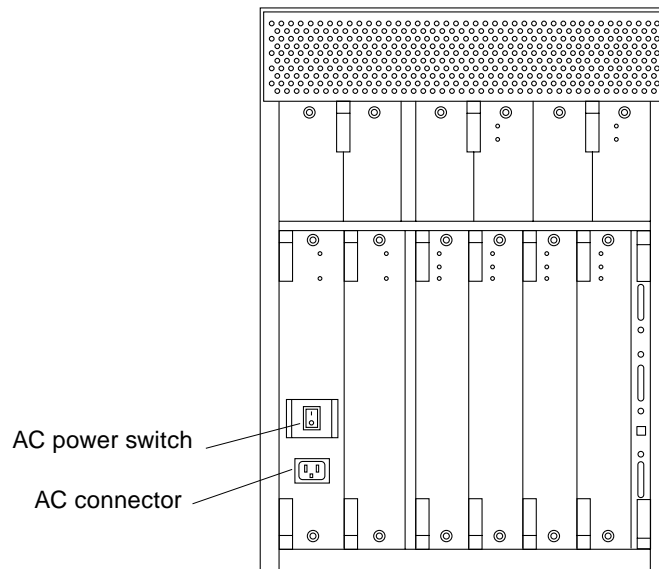

Figure 11-2 AC Power Switch and Power Receptacle

11.2 Removing the External Cables

1. **Position the server for easy access to the rear.**
2. **Disconnect each cable from the I/O boards carefully.**
Squeeze the locking tabs on the sides of the connector body, or loosen any retaining screws (if provided), and pull the connectors out.
3. **Mark each cable for identification as you remove it.**
4. **Remove any cable restraints.**
5. **Clear the cables away from the server.**

11.3 Restarting the System

Note – As the system starts up, watch for error messages from the POST diagnostic program. If a terminal is not already part of the system, install a TTY terminal before continuing the start up. See the *Ultra Enterprise 3000 System Installation Guide*.

1. **Use the handle on the front of the Ultra Enterprise 3000 system and pull the front door open.**
2. **Locate the system keyswitch in the upper right corner, and turn the key switch to the standby position (⏻).**
See Figure 11-1.



Caution – The outlet must be a 100-120 or 200-240 VAC 30-ampere circuit, intended solely for use by the server, as described in the site preparation instructions in the *Ultra Enterprise 3000 System Installation Guide*. The electrical receptacle must be grounded, and the grounding conductor serving this receptacle must be connected to the earth ground at the service equipment.

3. **Turn on the AC power sequencer power switch.**
See Figure 11-2.
4. **Turn on power to the terminal.**
A terminal is required for viewing system messages. For setup instructions, see Section 8.1, “Using a Terminal,” on page 8-1.
5. **Turn the key switch to the power-on position (⏻).**
See Figure 11-1. Several things will happen:
 - The left front panel LED (green) turns on immediately to indicate the DC power supply is functioning.
 - The middle front panel LED (yellow) lights immediately and should turn off after approximately 60 seconds.
 - The right front panel LED (green) flashes after POST has ended to show that booting is successful and the operating system is running.
 - The terminal screen lights up upon completion of the internal self test.



Warning – Never move the server or the expansion cabinets when system power is on. Excessive movement can cause catastrophic disk drive failure. Always power the system OFF before moving cabinets.

6. Watch the terminal screen for any POST error messages.

At the conclusion of testing, POST automatically configures the system, omitting any devices that have failed diagnostics. After POST ends, the system will boot using the new configuration.

Note – If the middle front panel LED (yellow) remains lit after the system has booted, the system has failed POST.

Note – POST does not test drives or internal parts of SBus cards. To test these devices, run OBP diagnostics manually after the system has booted. Refer to the *OpenBoot Command Reference* manual for instructions.

7. To start POST again, or if the system hangs, press the CPU reset switch on the clock board.

See Figure 11-3.

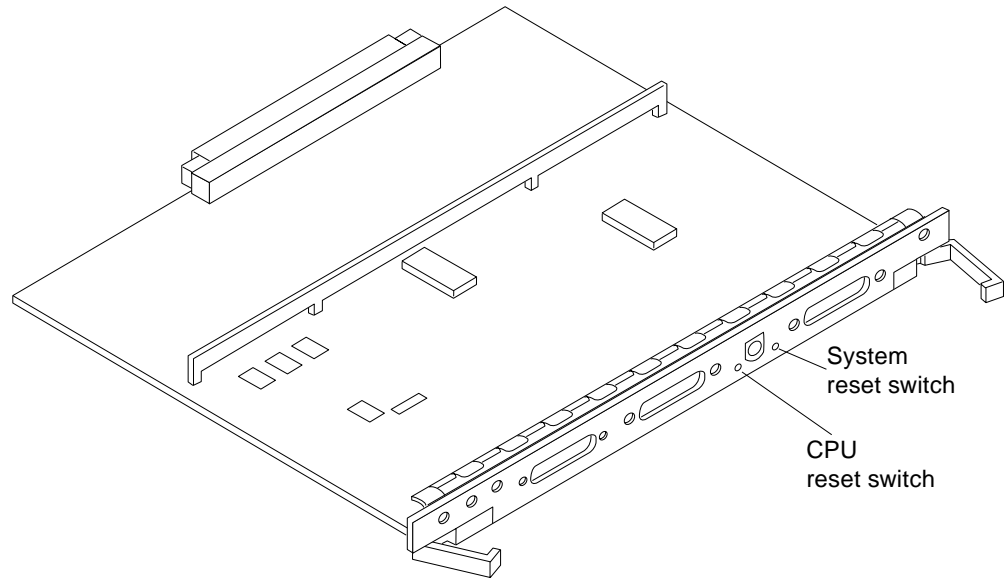

Figure 11-3 System Reset Switch on Clock Board

8. If the system displays “not responding” or “no carrier” messages, the Link Integrity Test may be set incorrectly. See “Link Integrity Test” on page 4-19.

11.4 Reading Boot Messages

- ◆ Use the boot software messages to verify the presence of options in the system. After POST completes the system self-test, a message similar to the following will appear on your screen. The message lists hardware detected in the system.

Note – The following screen display is only an example. The actual message displayed on the screen will vary with the software running on the system.

```
4-slot Ultra Enterprise 3000, Keyboard Present
OpenBoot -.- FCS, --- MB memory installed, Serial #---.
Ethernet address -:---:---:---:---, Host ID: -----.
```

If there is no terminal on this system, you must check the system status by inspecting LEDs on the front panel. See Figure 11-4.

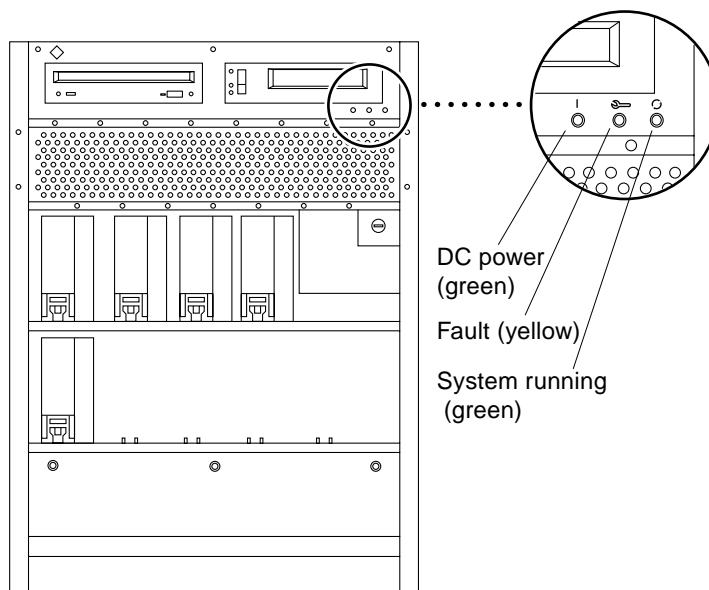

Figure 11-4 Front Panel Status LEDs

Table 11-1 summarizes the front panel LED status conditions during and after POST.

Table 11-1 LED Status Indicators

LED	Condition
Left LED (green)	On — DC power supply is receiving AC current. Off — There is no DC power.
Middle LED (yellow)	On flashing — (first 60 seconds) Self tests are running. Off — (after self tests end) No hardware failures. On — (after self tests end) Hardware failure was detected.
Right LED (green)	Off — (first 60 seconds) Self tests are running. On flashing— (after self tests end) System is running. Off — (after self tests end) System cannot run; repair is needed.