

Wire Attenuation and Power



This appendix describes wire attenuation and power source information requirements for using SunISDN.

Wire Attenuation

Table C-1 lists the acceptable attenuation specification at different operating frequencies.

Table C-1 Wire Attenuation

Frequency	256 KHz	512 KHz	772 KHz	1 MHz	4 MHz	10 MHz	16 MHz	20 MHz
Atten. (db/1000)	3.2	4.3	5.4	6.0	14	23	30	32
Next (dB) (crosstalk) (worst pair)	N/A	N/A	N/A	N/A	N/A	N/A	N/A	N/A

While it is possible for the interface to function with cable that has electrical characteristics that are not as stringent as those mentioned above, Sun suggests that the electrical specifications of the cable used be approximate to the specifications listed above.

Note – The 10 meter distance is for the cable that goes from the workstation to the wall. The distance from the NT to the workstation or phone can be up to about 1000 meters (1km) with appropriate wiring and termination resistors.

Power for TE and NT

SunISDN does not supply power for external TE or NT equipment. If a piece of TE or NT equipment requires power, it might be supplied as described below by a source other than your Sun equipment. Power for TE and NT equipment can be affected in several different ways. In ISDN, power feeding through the RJ45 connector can be achieved from three different power units, as shown in Figure C-1. This configuration is shown in greater detail in Figure C-2.

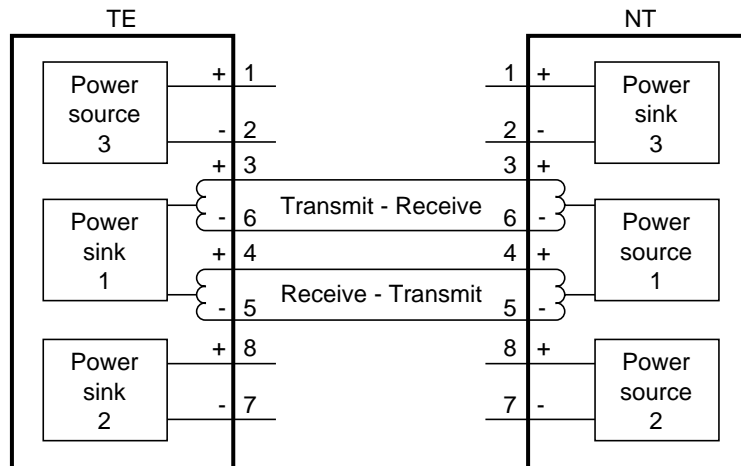

Figure C-1 Power Feeding

The idea behind feeding power to TE is that at least one TE must always be working, even when the power supply has failed to the building where the terminals are located. This state is called *restricted power condition*.

Normally, telephones work even if buildings are without power and it is this principle which is intended to be maintained.

Sun's implementation of ISDN neither uses nor supplies power on any of Power Source 1, 2, or 3. However, we do physically connect Power Source 1, 2, and 3 between the two interfaces so that if you have power supplied by some external device on one of the two interfaces, it will be available on the other.

Power Source 1

Power source 1 is the power feeding from the main power supply subscriber line (U interface, for example from your ISDN service provider) or a power source located in the NT. The local power source can be battery and/or AC power unit. The power is fed as a DC voltage difference between the transmit and receive signal pairs.

Under normal power conditions, the output voltage from the NT must be 40 VDC (+5%/ -15%) at a full power load.

Under *restricted power conditions*, the output voltage from the NT must be -40 VDC (+5%/ -15%) at a power load of 420 milliwatts.

A *restricted power condition* is detected when the NT changes polarity in the power feeding. This means that the power consumption must be low and communication can take place only from one terminal.

Power Source 2

Power source 2 is located locally in the NT1 and may consist of either an AC power unit or a battery. The maximum take-off from this power source is 7 watts at 40 VDC (+5%/ -15%).

Power Source 3

Power source 3 is designed for power feeding of TE to TE, or TE to NT and is not dealt with by the CCITT standard.

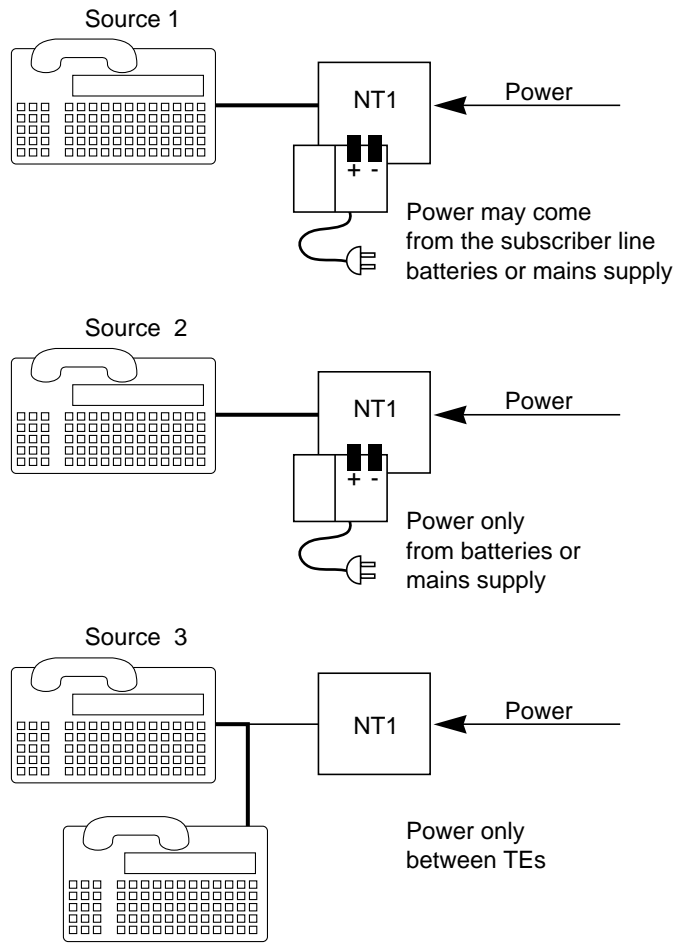

Figure C-2 Power Configurations