

SunISDN Line Configuration

The termination resistors are a physical component of the SunISDN communication wiring. The placement of the resistor and their values are defined in the CCITT I.430 recommendation. This specification tells you the maximum number of end terminators allowed for different types of network configurations.

Note – In most cases, you should not remove ISDN termination jumpers supplied with your system or SBus board. If you find intermittent connection to the network, check the jumpers. If they were not installed, add them according to the instructions in this chapter that apply to your system.

The wiring configuration needs a termination resistor pair at each end of the line only. See the CCITT I.430 recommendation for placement and resistor value. ISDN lines require 100 ohm termination resistors to be installed across the two pairs of signal lines at specific points in the wiring (for example, you always have a set of two resistors between two sets of wires in at least two different locations in the wiring). One set is near to or part of the NT device. In configurations where there is only one TE device (workstation, phone, FAX machine, and so on) connected to the line (as in an ISDN point-to-point configuration), a second set of termination resistors is placed near the TE device (it should be an integral part of the RJ45 socket that is in the wall). In non-point-to-point configurations, the position of the other termination resistor set is dependent on the wiring.

The only way to correctly determine where these resistors are to be placed is by having the wiring diagrams for the ISDN wiring installation. These termination resistors should be installed when the wiring is installed.

If the ISDN installation is not performed properly with respect to the termination resistors, it can result in a complete lack of or incorrect placement of termination resistors on the line, which can cause the ISDN connection to be intermittent or non-functional. Another possible indication of faulty wiring is the failure of your workstation to communicate over the ISDN line. Another is significantly lower than expected data throughput.

The SunISDN SBus board and SPARCstation systems are shipped with the termination resistors connected (see Note below). Having the termination pins installed ensures proper termination for the circuit. It is more likely that the interface will operate correctly with too many termination resistors than with too few. As a convenience to our customers, all ISDN products have the ability to have termination resistors placed in the line by setting two jumpers on the board with the ISDN interface.

Note – Early SPARCstation 10 and LX systems have shipped without the termination jumpers installed. It is recommended that the termination jumpers be connected as illustrated in Figure 3-2. If the problem persists after the adjustment is made to the jumper pin location, consult your local telephone company.

SPARCstation 10 Jumper Pins

Figure 3-1 and Figure 3-2 show the SPARCstation 10 jumper pin location. Figure 3-1 illustrates that there is no termination. Figure 3-2 shows terminated position with jumpers connected. Confirm that the jumpers were installed. Install them if they're missing.

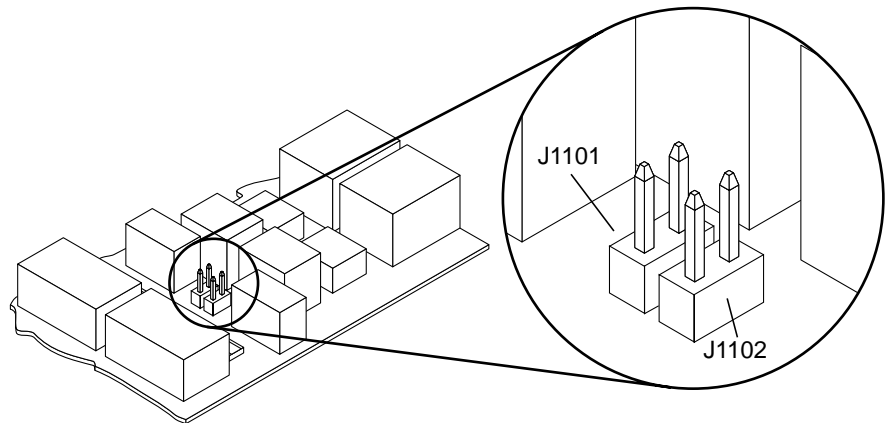

Figure 3-1 SPARCstation 10 Jumper Position 1 (Unterminated Position)

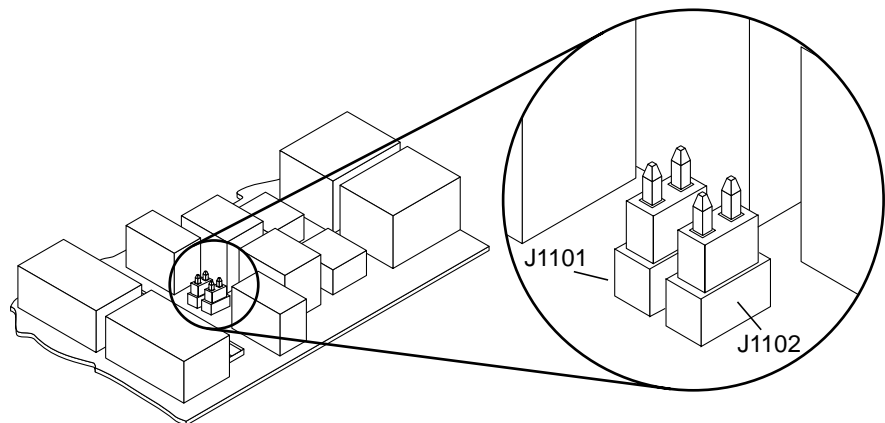

Figure 3-2 SPARCstation 10 Jumper Position 2 (Terminated Default Position)

SunISDN SBus Board Jumper Pins

Figure 3-3 illustrates the unterminated position with the jumpers between pins 2 and 3. Figure 3-4 shows terminated position with jumpers connected between pins 1 and 2.

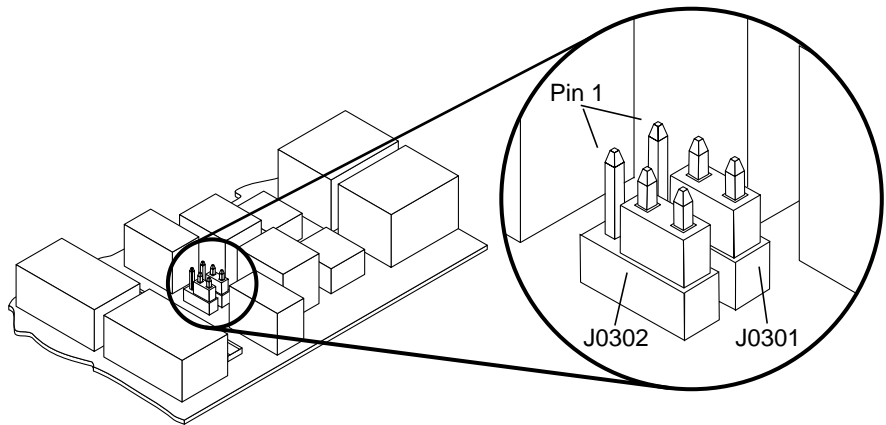

Figure 3-3 SunISDN SBus Board Jumper (Unterminated Position)

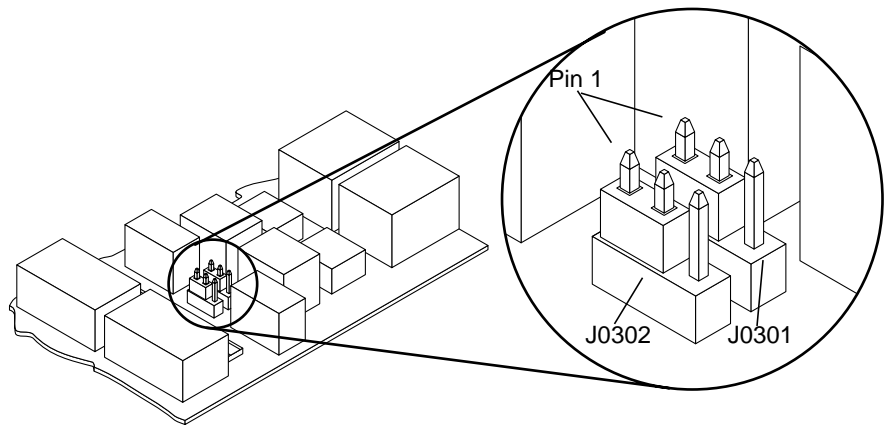

Figure 3-4 SunISDN SBus Board Jumper (Terminated Default Position)

SPARCstation LX Jumper Pins

The default terminated jumper position (position 2) for the SPARCstation LX is between pins 1 and 2. Position 1 (unterminated) is configured with the jumpers between pins 2 and 3. The location of the pins are on J1801 and J1802. Confirm that the jumpers are installed.

SPARCstation Voyager Jumper Pins

The default (terminated) jumper position for the SPARCstation Voyager is between pins 1 and 2. The locations of the pins are on J1400 and J1401. See Figure 3-5. To disable the termination, move both jumpers to pin 2 and pin 3.

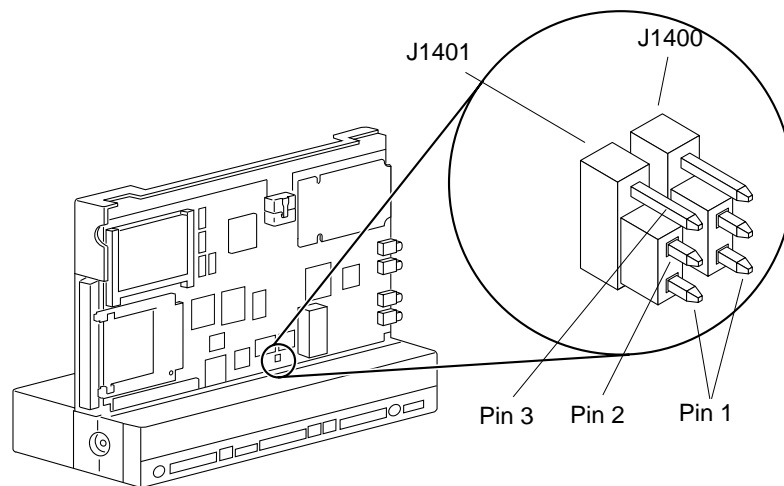

Figure 3-5 SPARCstation Voyager ISDN Jumper (Terminated Default Position)

What to Do if There is a Communication Problem

If you experience a communication problem over the ISDN line:

- Check that the ISDN cable is plugged all the way to the TE port.
- Check that the configuration of the termination resistor pins are as specified earlier in this chapter.
- Switch the jumper pin location to connect the termination resistors.